

INTEGRATED PROPULSION UNITS

A Proven Way to Reduce Fuel Consumption and Optimize Performance

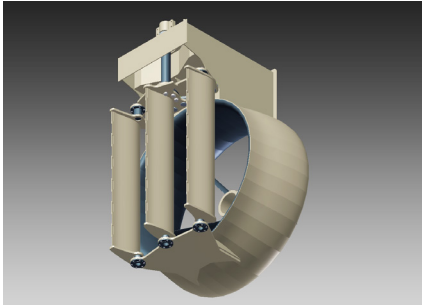

Nautican's integrated propulsion systems offer the greatest reduction of fuel consumption possible while delivering unparalleled power and maneuverability.

The Nautican Integrated Propulsion Unit combines High Efficiency Nozzles, Triple Rudders, Pre-Swirl Stators and Propellers for a level of performance that cannot be duplicated. The advanced airfoil design of the High Efficiency Nozzle has a proven 17 times less resistance than a conventional 19a KORT nozzle. The Pre-Swirl Stators further improve performance of the nozzle by four to six percent.

The integrated unit arrives fully assembled reducing shipyard installation time, while the high quality construction adds strength and durability to the Nautican system - furthering your investment with reduced maintenance costs.

The power, fuel efficiency and maneuverability gained with the Nautican unit make it ideal for strenuous shallow draft and inland conditions. We work with you to find the perfect solution for your fleet, whether on new construction or in modernizing an aging vessel.

FUEL EFFICIENCY GAINS BY VESSEL TYPE

Tug Boats	10 - 25 %
Push Boats	10 - 30 %
ATBs & Tankers	15 - 30 %
Ferries & Cruise Ships	10 - 20 %
Container Ships	10 - 30 %
Fishing Vessels	15 - 30 %
Yachts	10 - 20 %
SWAT Vessels	10 - 20 %

Integrated Propulsion Unit Helps Improve Vessel Performance of Ocean-Going Tug

When Young Brothers, Ltd., based in Honolulu, conducted an overhaul of its 108-foot, twin screw, ocean going tug, the *Hoku Ke'a*, the owners installed integrated Nautican High Efficiency Nozzles, Triple Rudders and Propellers to give the vessel the muscle to tow larger barges while at the same time maintaining inter-island transit times. This was the first installation of integrated Nautican Nozzles and Triple Rudders on an ocean going tug, and it resulted in:

- 10-12% increase in thrust
- 10% fuel savings
- 50% increase in pull

REQUEST AN OPERATIONAL ANALYSIS

We are happy to partner with you to help you determine the best solution for optimizing performance and reducing fuel consumption. By analyzing your fleet's operational needs, we can help you identify vessels that are the best candidates and assist you in determining the return on investment. Please fill out a form at <http://nautican.com/operational-analysis/> for each vessel you would like us to analyze.